

Wiring the electronics

The purpose of this document is to show how to connect all the basic electronics mentioned in the matching process including the servo and how to make them work with the receiver and transmitter. The idea is simple; the receiver needs to get information from the transmitter which it then uses to tell the rest of the electronics what to do.

This diagram shows the general idea of how they should be connected but note; it is not a diagram of how the circuit will look in all electronic planes.

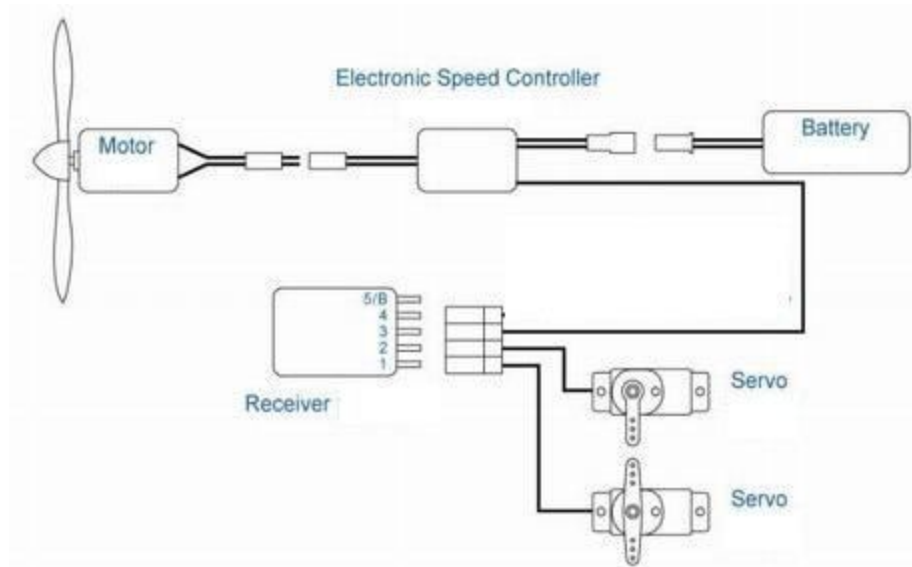

Fig 1.1

As you can see, the motor is connected to the ESC which has a battery eliminating circuit (BEC) that powers the receiver and servos all of which is powered by the battery connected to the ESC.

The Motor:

The prop for the motor must have the written values of its dimensions facing the direction in which the plane is moving, this is because the front surface is curved to give the plane more thrust (g) (explained in fluid dynamics). The motor is then connected to the ESC by 3 wires. One important thing that is easy to do is correct the direction in which the motor spins; this can be done by interchanging any two of the 3 wires that connect the ESC to the motor.

A safety measure that can be taken is not having the prop on the plane while testing the direction in which the motor is spinning to avoid injury or the plane taking off and crashing.

The Battery:

This is fairly simple because it only has two terminals that need to be connected to the ESC.

As a precaution, the battery must only be attached when testing to prevent it from heating or puffing up.

The ESC (electronic speed controller)

The ESC needs to be powered by the battery and it needs to be connected to the receiver and the motor as mentioned earlier. There are two kinds of ESCs; one with a BEC and one without it. The BEC is a circuit that allows the receiver and servos to run off the the same battery that powers the rest of the plane. If your ESC does not have a BEC, then it will require a separate battery to power the receiver hence the circuit's name (Battery eliminating circuit).

The Receiver :

This is the device that tells the rest of the electronics what to do based of information given from the transmitter by the user. Each component that need to be connected to it will get a set of 3 pins that are the two terminals + and – and the signal wire given by Ω (omega symbol). The manufacturer would have already specified which component goes where. Example: servos for the ailerons, rudders and elevators; something that is different for most receivers but the idea is the same. Note: the two common wire colours for the signal wires are orange and white.

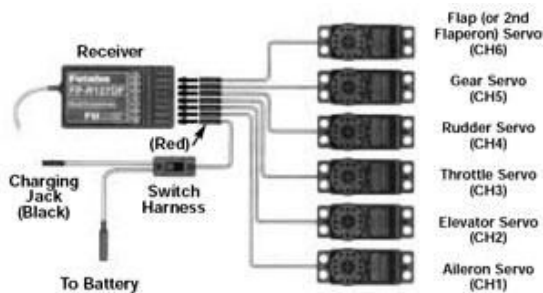

From Futaba 6EXA Manual

Fig 1.2

This is an example of how the servos may be connected to each of the connectors of the receiver as labelled in the diagram.

Some receivers may have the connectors to the ailerons, rudder and elevators have symbols or numbers as in the following case. (Here, the manufacturer will tell you which one is which)

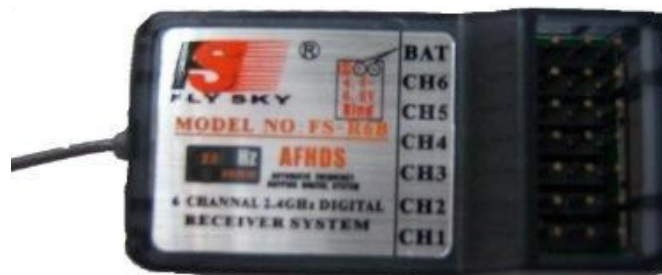

Fig 1.3